

# Parts Manual

Mfg. No: 1172-2  
2,250 PSI





---

<b>Model Components</b>	<b>Page</b>
Pressure Washer.....	4
Pump.....	8
Torque Specification Chart.....	12

Not For  
Reproduction

# Pressure Washer

Note: Unless noted otherwise, use the standard torque specifications

Mfg. No: 1172-2

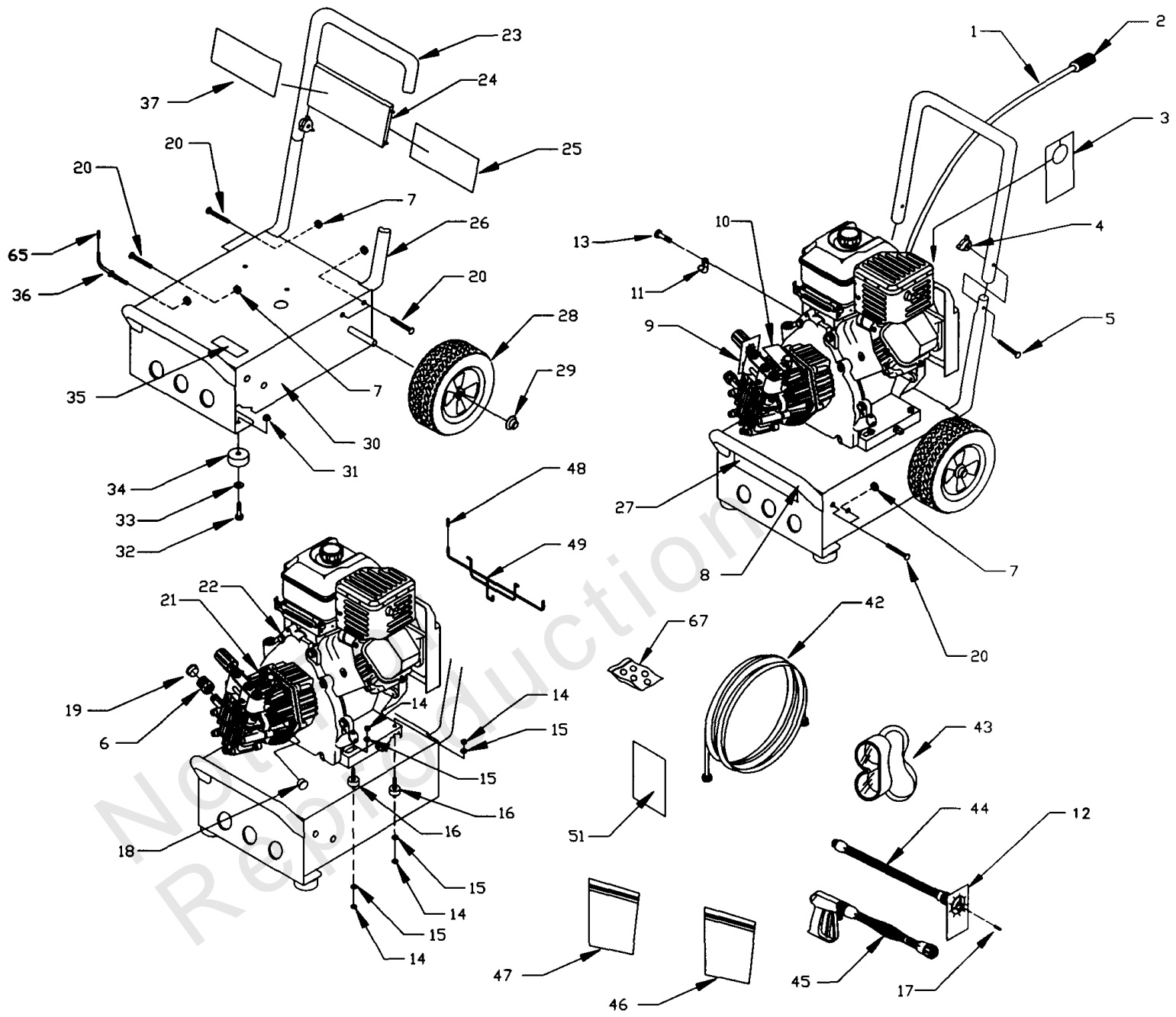

## Pressure Washer

REF NO	PART NO	QTY	DESCRIPTION
1	A1040D	1	HOSE, 4-1/2' Chemical Clear
2	A1041	1	FILTER, Chemical Hose
3	94481	1	TAG, Warning Oil -(English/French)
4	97178	2	KNOB, Handle 1/4 - 20 PW
5	31669	2	BOLT, 1/4 - 20 x 1-3/4 Carriage
6	21424	1	CONNECTOR, Garden Hose
7	99583	8	NUT, Flange Lock 5/16-28
8	B1982	1	BUMPER
9	98944	1	TAG, Pres. Adjust -(English/French)
10	B1288	1	TAG, PW Breather Cap -(Tri-Lingual)
11	B2718	1	CLAMP, Hose 7/16" Dia.
12	98904	1	TAG, Nozzle
13	32713	1	SCREW, Taptite #10 - 32 x 5/8" Lg
14	45771	8	NUT, M8-1.25 Hex
15	22129	8	LOCKWASHER, M8
16	21217	4	MOUNT, Rubber Shock
17	B1236F	1	NOZZLE, Replacement 1.25 mm
18	97100	1	CAP, H.P. Adaptor
19	A1408	1	CAP, Garden Hose Inlet
20	B2043	7	BOLT, 5/16 - 18 x 1-3/4" Carriage
21	----	1	ASSEMBLY, Pump -(see pump exploded view)
22	B1827	1	ENGINE
23	B1983	1	HANDLE
24	B1631A	1	BILLBOARD, Plastic
25	B2772	1	DECAL, Instructions
26	B1981	2	SUPPORT, Handle
27	B2192	1	DECAL, Generac
28	B1760	2	ASSEMBLY, 10" Tire & Wheel
29	75402	2	PUSHNUT, .50 Dia.
30	AB1770	1	BASE
31	52858	2	NUT, M8 1.25 Locking
32	42909	2	HHCS, M8 1.25 x 30
33	50190	2	WASHER, M8 Flat
34	27007	2	MOUNT, Donut Type Vibration
35	20566	1	DECAL, Generac #1-800 -(English)
36	B2150	1	HOOK, Gun
37	B2146	1	DECAL, Logo
42	B1969	1	HOSE, High Pressure
43	87815	1	GOGGLES, Safety
44	B1867F	1	WAND
45	B1861	1	GUN, High Pressure
46	B2203	1	KIT, Handle Fastening
47	B2163	1	KIT, Cleaning
48	B1460	2	CAP, Vinyl (black)
49	B2168	1	HANGER, Hose, Gun, Jug
51	98906	1	SHEET, Nozzle Cleaning, -(French)
65	B2516	1	CAP, Vinyl (black)

# Pressure Washer

Note: Unless noted otherwise, use the standard torque specifications

Mfg. No: 1172-2

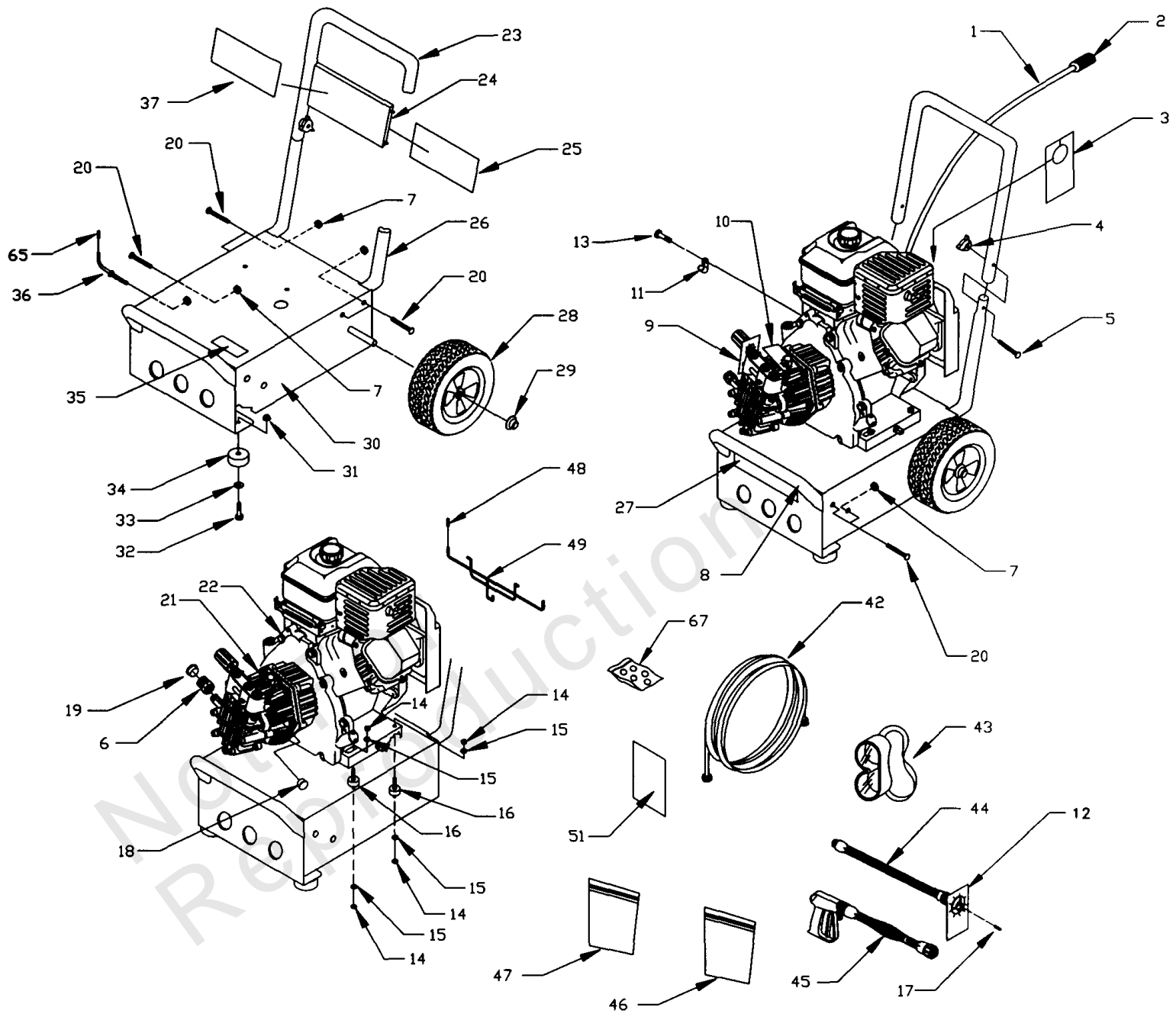

***Pressure Washer***

---

REF NO	PART NO	QTY	DESCRIPTION
67	B3057	1	KIT, O-Ring

---

Not For Reproduction

# Pump

Note: Unless noted otherwise, use the standard torque specifications

Mfg. No: 1172-2

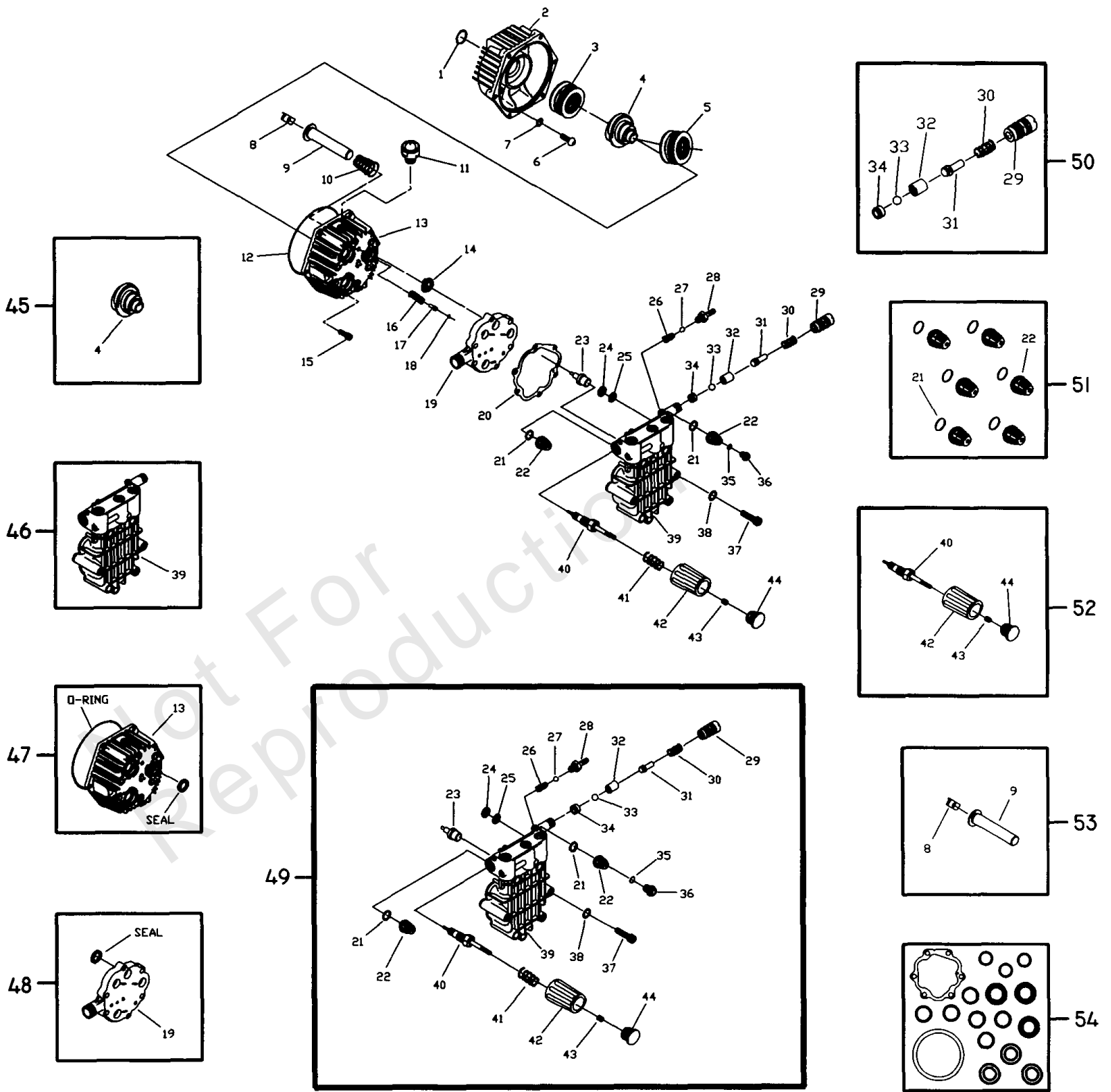



## Pump

REF NO	PART NO	QTY	DESCRIPTION
1	B2218	1	O-RING, 1.625" x 0.103
2	B2260	1	ADAPTER, Engine
3	96542	1	BEARING, Eng. Adptr. Roller Thrust 4 x 4
4	B3326	1	CAM, Axial 7.5 Lift
5	97606	1	BEARING, Axial Cam Roller Thrust 55 x 4
6	B2261B	4	SCREW, Button Hd 5/16 - 24 x 3/4" Lg
7	B2217	4	O-RING, 0.239 ID x 0.070
8	94944	3	SHOE, Piston Pivot
9	99427	3	ASSEMBLY, Ceramic Piston & Cap
10	96400	3	SPRING, Piston Return
11	99735	1	ASSEMBLY, Breather
12	93790	1	"O" RING, Crankcase 113.97 x 119.21 x 2.62
13	B2016	1	CRANKCASE ASSEMBLY
14	93668	3	SPACER, Pilot
15	40945	6	SCREW, SHC M6 x 1.0 x 20 mm Lg
16	93652	1	SPRING, Thermal Relief Actuator
17	95416	1	PISTON, Thermal Relief Actuator
18	93876	1	"O" RING, Thermal Relief 2.9 x 6.5 x 1.78
19	B2015	1	SPACER ASSEMBLY
20	A2069	1	GASKET, Head
21	97934	6	O - RING, Check Valve
22	B1449	6	CHECK VALVE, Inlet and Outlet
23	93644	1	ACTUATOR, Thermal Relief
24	96053	3	SEAL, High Pressure
25	96015	3	RING, Bearing
26	95380	1	SPRING, Chemical Injector
27	95379	1	BALL, 5.5 dia. Chemical Injector
28	A1575	1	BARB HOSE, Brass with Nylon Insert
29	B2151	1	VENTURI ASSEMBLY
30	89138	1	SPRING, Check Valve
31	B1879	1	SHUTTLE PISTON ASSEMBLY
32	A2503	1	SEAT, Trapped Line Pressure
33	A2015	1	BALL, Stainless Steel 9/32 Dia.
34	B2152	1	BALL SEAT ASSEMBLY
35	97840	3	"O" RING, Chk Valve Cap 15.6 x 19.16 x 1.78
36	97841	3	CAP, Outlet Port
37	A2013	6	BOLT, Head M8 x 1.25 x 70mm Lg
38	B2665	6	WASHER, Steel Special
39	B3148	1	HEAD ASSEMBLY
40	B3185	1	UNLOADER SPINDLE ASSEMBLY
41	A1716	1	SPRING, Unloader
42	B3117	1	HANDLE, Unloader
43	A2014	1	SET SCREW, M6 - 1.0 x 8mm
44	B2241	1	CAP, Plastic
45	B3511	0	CAM ASSEMBLY, 7.5 LIFT -Service Kits
46	B3507	0	HEAD ASSEMBLY -Service Kits
47	B3508	0	CRANKCASE ASSEMBLY -Service Kits
48	B3509	0	SPACER PLATE ASSEMBLY -Service Kits

# Pump

Note: Unless noted otherwise, use the standard torque specifications

Mfg. No: 1172-2

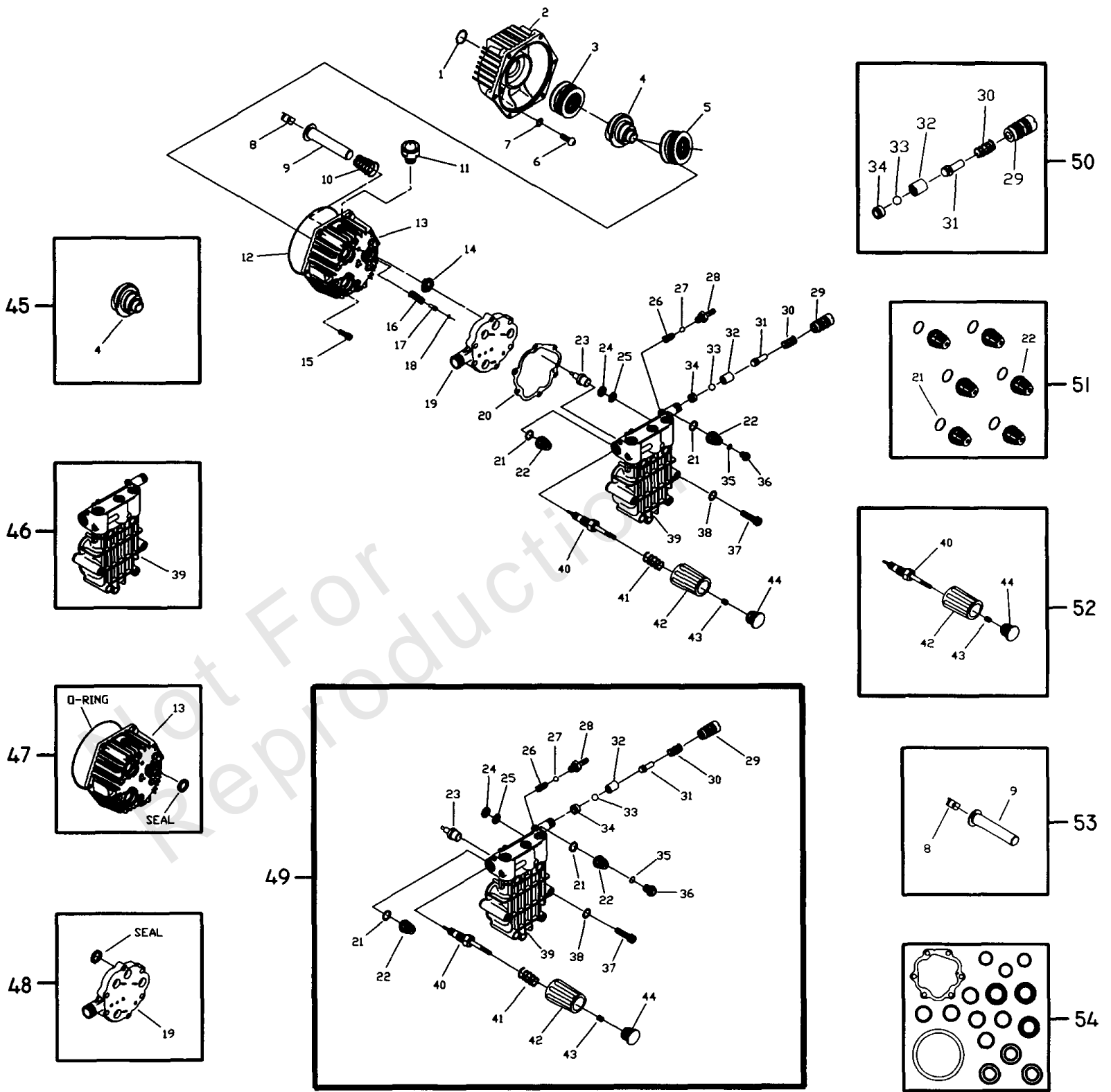

## Pump

REF NO	PART NO	QTY	DESCRIPTION
49	B3480	0	COMPLETE HEAD ASSEMBLY -Service Kits
50	B3510	0	HIGH PRESSURE OUTLET ASSEMBLY -Service Kits
51	B3513	0	CHECK VALVE ASSEMBLY, 6 pkg. -Service Kits
52	B3479	0	UNLOADER SPINDLE ASSEMBLY -Service Kits
53	B3478	0	PISTON SHOE ASSEMBLY -Service Kits
54	B3514	0	O-RING/SEAL KIT -Service Kits

Not For Reproduction

# Hardware Identification & Torque Specifications

Torque Specification Chart								
FOR STANDARD METRIC MACHINE HARDWARE (Tolerance ± 20%)								
Property Class	5.6		8.8		10.9		12.9	
	Class 5.6		Class 8.8		Class 10.9		Class 12.9	
Size Of Hardware	in/lbs	Nm.	in/lbs	Nm.	in/lbs	Nm.	in/lbs	Nm.
	ft/lbs		ft/lbs		ft/lbs		ft/lbs	
M3	5.88	.56	13.44	1.28	19.2	1.80	22.92	2.15
M4	13.44	1.28	30.72	2.90	43.44	4.10	52.56	4.95
M5	26.4	2.50	60.96	5.75	5.97	8.10	7.15	9.7
M6	44.64	4.3	7.3	9.9	10.3	14	12.1	16.5
M7	5.2	7.1	12.1	16.5	16.9	23	19.9	27
M8	7.7	10.5	17.7	24	25	34	29	40
M10	15	21	35	48	50	67	59	81
M12	26	36	61	83	86.2	117	103	140
M14	42	58	101	132	136	185	162	220
M16	64	88	147	200	210	285	250	340
M18	89	121	202	275	287	390	346	470
M20	126	171	290	390	405	550	486	660
M22	169	230	390	530	559	745	656	890
M24	217	295	497	375	708	960	840	1140
M27	320	435	733	995	1032	1400	1239	1680
M30	435	590	995	1350	1401	1900	1681	2280
M33	590	800	1349	1830	1902	2580	2278	3090
M36	759	1030	1740	2360	2441	3310	2935	3980
M39	988	1340	2249	3050	3163	4290	3798	5150

Torque Specification Chart						
FOR STANDARD MACHINE HARDWARE (Tolerance ± 20%)						
Hardware Grade	No Marks		SAE Grade 5		SAE Grade 8	
	SAE Grade 2		SAE Grade 5		SAE Grade 8	
Size Of Hardware	in/lbs	Nm.	in/lbs	Nm.	in/lbs	Nm.
	ft/lbs		ft/lbs		ft/lbs	
8-32	19	2.1	30	3.4	41	4.6
8-36	20	2.3	31	3.5	43	4.9
10-24	27	3.1	43	4.9	60	6.8
10-32	31	3.5	49	5.5	68	7.7
1/4-20	66	7.6	8	10.9	12	16.3
1/4-28	76	8.6	10	13.6	14	19.0
5/16-18	11	15.0	17	23.1	25	34.0
5/16-24	12	16.3	19	25.8	29	34.0
3/8-16	20	27.2	30	40.8	45	61.2
3/8-24	23	31.3	35	47.6	50	68.0
7/16-14	30	40.8	50	68.0	70	95.2
7/16-20	35	47.6	55	74.8	80	108.8
1/2-13	50	68.0	75	102.0	110	149.6
1/2-20	55	74.8	90	122.4	120	163.2
9/16-12	65	88.4	110	149.6	150	204.0
9/16-18	75	102.0	120	163.2	170	231.2
5/8-11	90	122.4	150	204.0	220	299.2
5/8-18	100	136	180	244.8	240	326.4
3/4-10	160	217.6	260	353.6	386	525.0
3/4-16	180	244.8	300	408.0	420	571.2
7/8-9	140	190.4	400	544.0	600	816.0
7/8-14	155	210.8	440	598.4	660	897.6
1-8	220	299.2	580	788.8	900	1,244.0
1-12	240	326.4	640	870.4	1,000	1,360.0

The guides and ruler furnished below are designed to help you select the appropriate hardware.



Nut, M8

Thread Diameter (mm)

Inside Diameter (in)      Threads per inch

Nut, 1/2-16

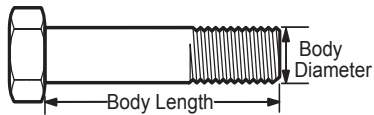

Screw, M8- 1.25 x 25

Thread Diameter (mm)      Distance between threads (mm)      Body Length (mm)

Body Diameter      Threads per inch      Body Length (in)

Screw, 1/2- 16 x 2

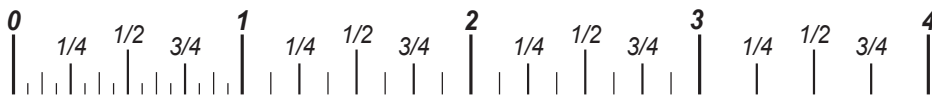

## Standard Hardware Sizing

When a washer or nut is identified as 1/2" (M8), this is the *Nominal size*, meaning the *inside diameter* is 1/2 inch (8mm metric thread diameter); if a second number is present it represents the *threads per inch* (distance between threads).

When bolt or capscrew is identified as 1/2 - 16 x 2" (M8 - 1.25 x 50), this means the *Nominal size*, or body diameter is 1/2 inch (8mm metric thread diameter), the second number, 16, represents the *threads per inch*, (*distance between threads*). The final number is the body length of the bolt or screw, 2 inches (50mm).

## NOTES

- These torque values are to be used for all hardware excluding: locknuts, self-tapping screws, thread forming screws, sheet metal screws and socket head setscrews.
- Recommended seating torque values for locknuts:
  - for prevailing torque locknuts - use 65% of grade 5 torques.
  - for flange whizlock nuts and screws - use 135% of grade 5 torques.
- Unless otherwise noted on assembly drawings, all torque values must meet this specification.

## Common Hardware Types

Hex Head Capscrew

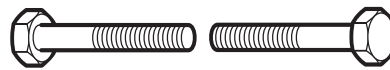

Washer



Carriage Bolt

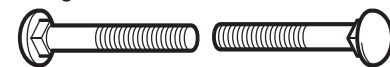

Hex Nut

## Wrench & Fastener Size Guide

1/4" Bolt or Nut Wrench—7/16"	5/16" Bolt or Nut Wrench—1/2"	3/8" Bolt or Nut Wrench—9/16"	7/16" Bolt or Nut Wrench (Bolt)—5/8" Wrench (Nut)—11/16"	1/2" Bolt or Nut Wrench—3/4"
M6 Bolt or Nut Wrench—10mm	M8 Bolt or Nut Wrench—13mm	M10 Bolt or Nut Wrench—17mm	M12 Bolt or Nut Wrench—19mm	M14 Bolt or Nut Wrench—22mm

